

Exploded View

PPA1210M

115V~ 60Hz 1Phase

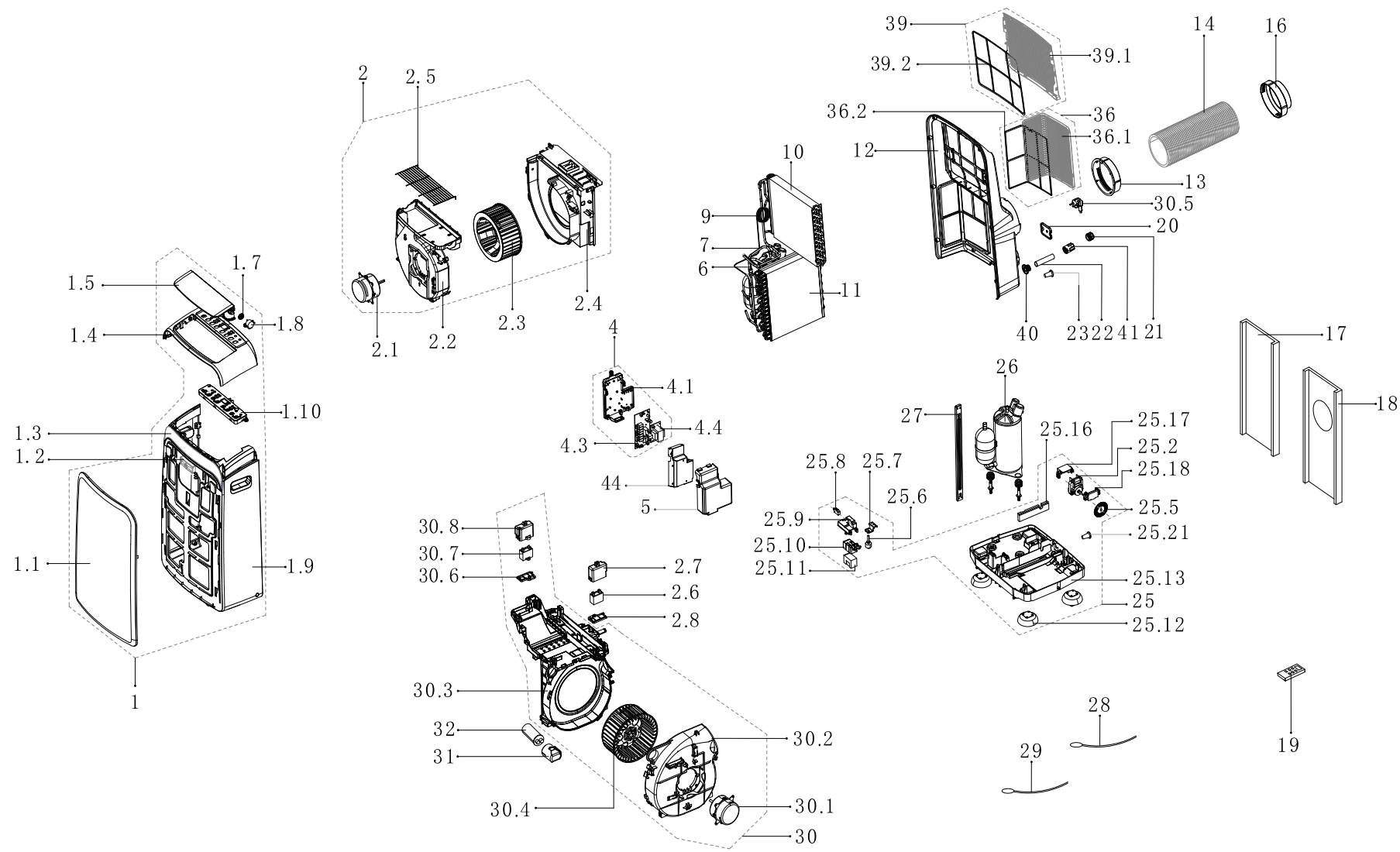

No.	Part Name	Quantity	BOM Code	Remark
1	Front Side assembly	1.0	12120600001112	
1.1	Front Side	1.0	12120600001065	
1.2	Components of remote control r	1.0	17120600000020	
1.3	Decorative sheet	1.0	12120600000751	
1.4	Upper Front Panel	1.0	12120600001244	
1.5	Wind Guide	1.0	12120600000007	
1.7	Gear	1.0	12120600000004	
1.8	stepper motor	1.0	11002010000176	
1.9	Middle Panel	1.0	12120600000749	
1.10	Structure Subassembly of Displ	1.0	17220600000081	
2	Assembly of Fan Shell	1.0	12120600000921	
2.1	Single-phase Asynchronous Moto	1.0	11002012002503	
2.2	Fan Shell Subassembly	1.0	12120600000925	
2.3	Centrifugal Fan	1.0	12100103000044	
2.4	Fan Shell Cover	1.0	12120600000896	
2.6	Motor Capacitor	1.0	17400101000008	
2.7	Capacitor Cover	1.0	12120600001475	
2.8	Capacitor Clip	1.0	12120600001476	
4	E-Parts Box Subassembly	1.0	17220600000114	
4.1	Bottom of E-Parts Box	1.0	12120600000397	
4.3	Main Control Board Subassembly	1.0	17120600000178	
4.4	Linear Transformer	1.0	11203103000554	
5	Electrical Control Box Cover	1.0	12120600000401	
6	Parts of compressor return pip	1.0	15120600000355	
7	Parts of compressor exhaust pi	1.0	15120600000315	
9	Capillary Assembly	1.0	15120600000456	
10	Evaporator assembly Gas valve	1.0	15820600000011	

11	Condenser Assembly	1.0	15820600000271
12	Rear Panel assembly	1.0	12120600000529
14	Flexible air exhaust hose	1.0	12100508000013
16	Air Outlet Tie-in	1.0	12100506000011
17	Sealing Board	1.0	12120600000444
18	Sealing Board	1.0	12120600000448
19	Remote controller	1.0	17317000000100
20	Power Supply Cable Patch	1.0	12120600000032
22	Drain pipe	1.0	12100509000040
23	Drain Stopper	1.0	12600801000048
24	Water Drain Connector	1.0	12120600001492
24	Water Drain Connector	1.0	12120600001497
25	Chassis assembly	1.0	12120600002119
25.2	Shaded Pole Motor	1.0	11002017000785
25.5	Water Wheel	1.0	12120600000250
25.6	Water Level Switch	1.0	17400511000003
25.7	Supporting for Water Depth Sen:	1.0	12220600000265
25.8	Micro Switch	1.0	17400512000001
25.9	Micro switch support	1.0	12120600001417
25.10	Floater box	1.0	12120600001259
25.11	Floater foam	1.0	12820600000007
25.12	Universal wheel	4.0	12620600000019
25.13	Chassis Subassembly	1.0	12120600001649
25.16	Water Retaining Foam	1.0	12820600000003
25.17	Upper Holder for Water Motor	1.0	12120600001411
25.18	Lower Holder for Water Motor	1.0	12120600001399
25.21	Drain Stopper	1.0	12600801000048
26	Fixed speed rotary compressor	1.0	11103010000714
27	Supporting bar	1.0	12220600000075
28	Temperature Sensor	1.0	11201007000124
29	Room Temperature Sensor	1.0	11201007000073
30	Exhaust Volute Subassembly	1.0	12120600000830
30.1	Single-phase Asynchronous Moto:	1.0	11002012004394
30.2	Exhaust scroll cover	1.0	12120600000886
30.3	Parts of middle clapboard	1.0	12120600000028
30.4	Centrifugal Fan	1.0	12100103000069
30.5	Power Supply Cable Subassembly	1.0	17401202000193
30.6	Capacitor Clip	1.0	12120600001476
30.7	Capacitor	1.0	17400101000071
30.8	Capacitor Cover	1.0	12120600001475
31	Capacitor Cap	1.0	12120600001477
32	Compressor Capacitor(Round)	1.0	17400103000063
36	Outer Air Inlet Frame Assembly	1.0	12120600000560
36.1	Air Inlet Frame of Outer Side	1.0	12120600000573
36.2	Filter	1.0	12120600000661
39	Inner Side Air Inlet Frame assl	1.0	12120600000598
39.1	Air Inlet Frame of Inner Side	1.0	12120600000647
39.2	Inner side of filter	1.0	12100204000251
40	Connector of Water Drain Pipe	1.0	12120600001495
44	Electrical Control Box Cover	1.0	12220600000060